

ECM Connector

Note: All empty cavities require plug

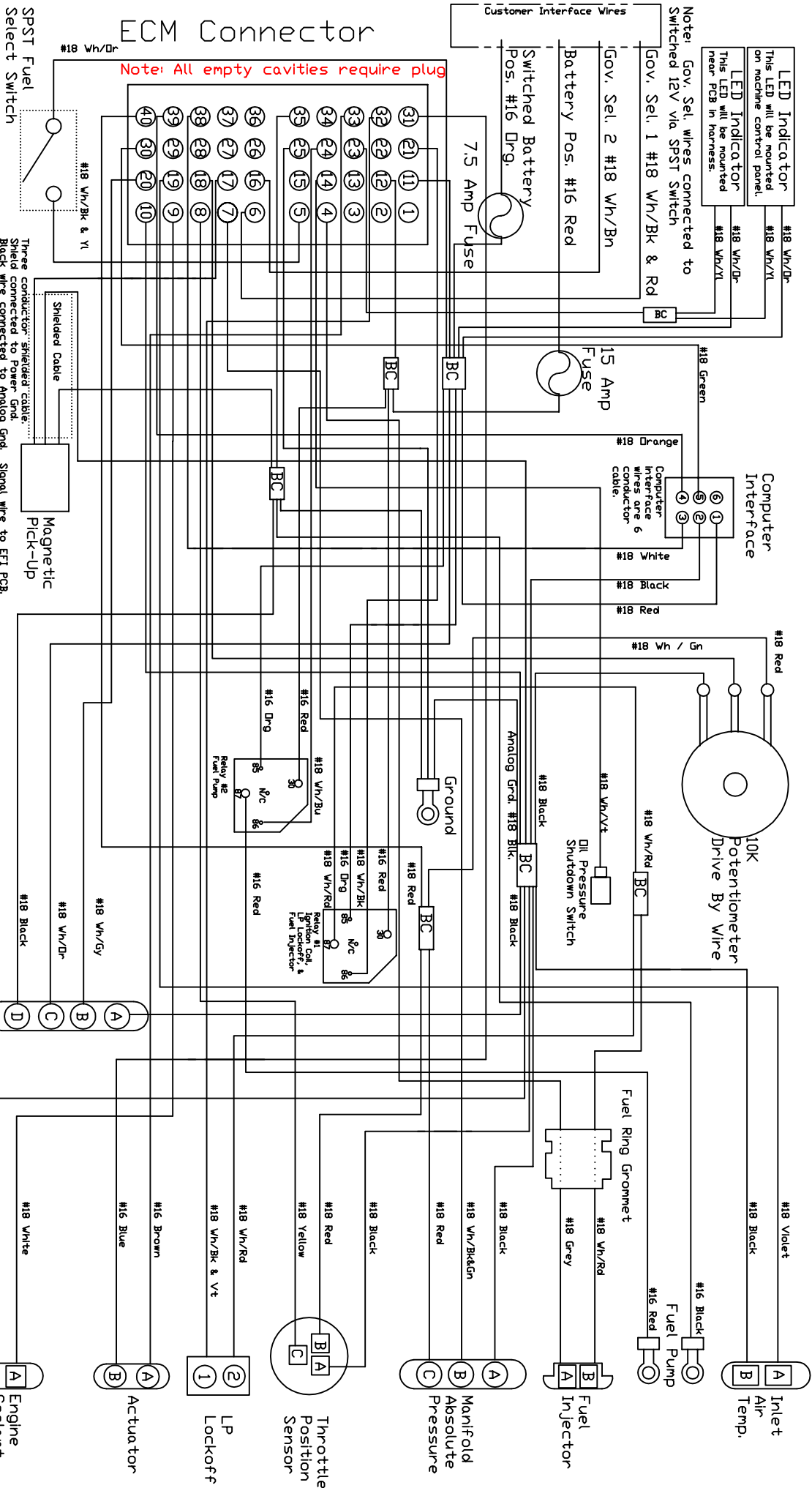

Description	Mfg.	PN#	QTY.	Description	Mfg.	PN#	QTY.
Fuel Select Switch	SPST	SVI	1	Actuator Connector	Pioneer/Packard	12015792	1
Computer Connector	Deutsch	DT06-6S	1	Actuator Connector Terminal	Pioneer/Packard	12089188	2
Computer Connector Terminal	Deutsch	0462-201-16141	5	Pioneer/Packard	Pioneer/Packard	12015325	2
Computer Connector Wedge	Deutsch	V6S	1	Engine Coolant Temp. Conn.	Pioneer/Packard	12162193	1
Air Inlet Temp. Connector	Pioneer/Packard	12162197	1	Eng. Coolant Temp. Terminal	Pioneer/Packard	12124075	2
Air Temp. Connector Terminal	Pioneer/Packard	12124075	2	Relays	Pioneer/Packard	12193620	2
Injector Connector	Pioneer/Packard	12162215	2	Relay Connector	Pioneer/Packard	12110539	2
Injector Connector Terminal	Pioneer/Packard	12089340	2	Relay Connector Terminals	Pioneer/Packard	12110847	8
MAP Sensor Connector	Pioneer/Packard	12020403	2	ECM Connector	Pioneer/Packard	12110540	2
MAP Sensor Connector Terminal	Pioneer/Packard	12015323	3	ECM Connector Terminal	Deutsch	DRC16-40S	1
MAP Sensor Weather Seal	Pioneer/Packard	12055887	3	Deutsch	0462-201-16141	28	
Tps Connector	Pioneer/Packard	12103881	3	Pioneer/Packard	12162144-B	1	
Map Pick-Up Connector	Pioneer/Packard	12101973	3	Pioneer/Packard	12048074-L	4	
Map Pick-Up Seal	Pioneer/Packard	12015323	2	Pioneer/Packard	12047948-B	1	
Map Pick-Up Terminal	Pioneer/Packard	12089340	2	DIK Pressure Shutdown Switch	Pioneer/Packard	12048086-B	4
DIK Pressure Shutdown Switch	Female Snop Plug	12089340	2	LED Indicator	Network	609-2112-130	2
Fuel Ring Grommet	Pioneer/Packard	12052891	1	LP Lockoff Connector	Deutsch	DT06-2S	2
Potentiometer	Pioneer/Packard	RV4NAY31003A	1	LP Lockoff Conn. Terminal	Deutsch	0462-201-16141	2
				LP Lockoff Connector Wedge	Deutsch	V6S	1

Part Name: Precision Governors, LLC

Part Number: EFI WIRE HARNESS SCHEMATIC

Date: 10/29/02

Scale: None

Material or Specification: Nissan H25 Dual Fuel

Part Number: 7660

Drawn by: PAH