

ELECTRIC GOVERNOR INSTALLATION MANUAL

Model SA Actuator or Model SF Actuator

Used with a

Model E-331 Controller

GENERAL

The following information is intended as an aid to properly applying a Precision Governor Electric Governor. Since these governors are used on a wide range of engines in many different applications, much of the information is somewhat general in nature. If you need assistance concerning a specific detail on your application, please consult Precision Governors Application Engineering at 815/229-5300.

These instructions presume no electrical test equipment other than a multimeter for making the electrical measurements called for on the following pages. If no suitable meter is available, an inexpensive but adequate meter, part number 22-188 is available from any local Radio Shack store.

Many "governor problems" turn out to be installation problems, particularly in first-time applications. Careful attention to the directions provided will go far toward a successful installation made in the least amount of time.

QUICK-START INSTRUCTIONS

If you are experienced in installing and adjusting Electric Governors, follow these steps. Otherwise, refer to the more detailed instructions which begin on Page 2, starting with "MOUNTING-ACTUATOR".

- 1) Mount Actuator rigidly to engine in a location which will permit a short, straight linkage to the carburetor or fuel valve. Avoid very hot areas.
- 2) Mount Controller in a dry, fairly cool location. Accessibility for adjusting is required.
- 3) Wire per appropriate schematic, using #16 wire.
- 4) Set up fuel linkage. This is critical, so review the section titled "LINKAGE", Page 3.
- 5) Hold linkage for safety, and start engine.
- 6) Adjust engine speed to desired value using **Speed-set** pot. (See figure on page 6.)
Turn CW to increase, CCW to decrease speed.
- 7) Set **Gain** as required, using **Gain** pot. (See page 6.) CW increases sensitivity.
Load and unload engine to check for proper gain. Also, pull back Governor arm slightly and release.

MOUNTING-ACTUATOR

The Actuator may be mounted in any attitude-- there is no preferred orientation. Construct a simple, rigid bracket to mount the unit to the engine. 1/4" steel plate is recommended for bracket material. Use braces as required to insure rigidity. There can be no relative motion between the Actuator and engine, even during extremes of vibration and engine loading.

Avoid mounting the Actuator adjacent to exhaust system parts and other hot components. Extremely high temperatures will reduce the force available from the Actuator, in addition to shortening its life cycle.

With no power applied, the Actuator is spring-loaded to the minimum fuel position. The Actuator output shaft rotates toward the maximum fuel position against this spring through electrical power from the Controller. This rotation is CW(clockwise) on one side of the Actuator, and CCW(counter-clockwise) on the other. If necessary, reverse the Actuator on its mounting plate so that the desired direction of rotation is on the desired side to match the fuel system direction of travel.

Before selecting the mounting location, consider the linkage that will be required to connect the Actuator output arm to the butterfly or fuel valve. Read the following section on linkages before deciding on a mounting location!

LINKAGE

1/4" -28 threaded rod and low friction rod-end bearings are recommended for linkage materials.

Keep the linkage as short and as straight as possible. "Dog leg" linkages seldom work as desired, and generally are to be avoided.

The linkage **must not** rub against the engine, brackets, hoses, etc. The linkage **must** be free of friction and lost motion or "slop".

The following sketch indicates the proper linkage geometry for most installations.

1)

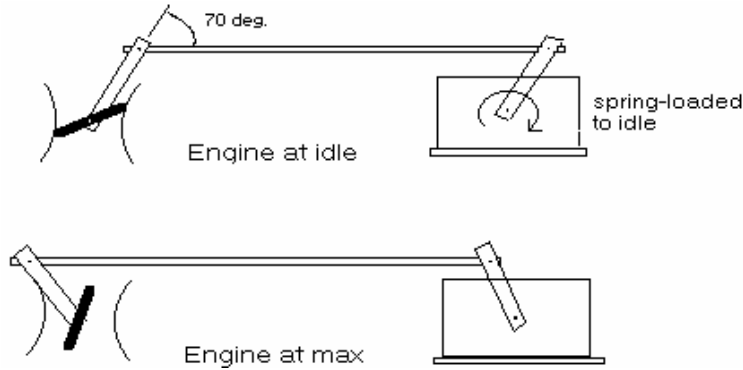

Note that the angle between the carburetor arm and the rod is **70 degrees** with the engine at idle. This is **highly** desirable! Note also that the Actuator arm travels equally on either side of a 90 deg. angle with the rod. This angular arrangement will give the proper mechanical gain for good stability and performance. It may be necessary to rotate the carburetor arm relative to the butterfly to achieve this. This can usually be done, and is usually worth the effort! Below are some workable installations, with good linkages. Remember, the Actuator can be turned 180 deg. on its mounting to "reverse" the spring-loaded direction. Also, the Actuator can be mounted in any attitude.

1)

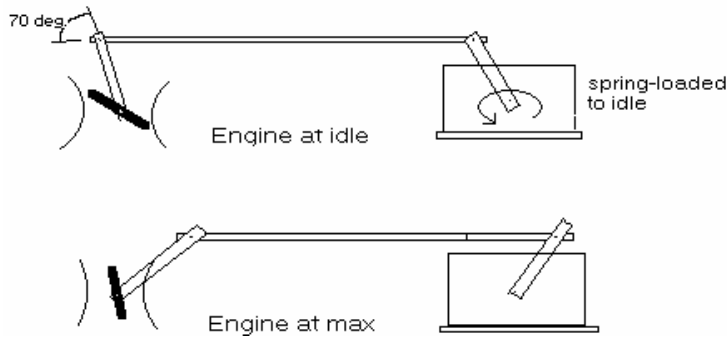

2)

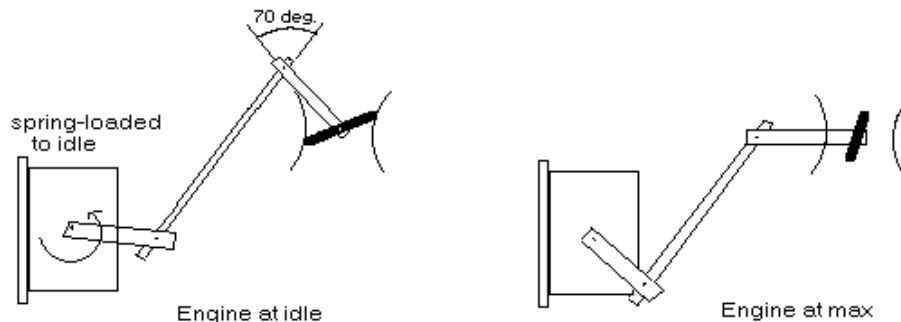

The needed **travel** of the carburetor determines how far out on the Actuator arm the rod is to be attached. In most cases, the carb should be moved from closed to about 10 degrees from full open as the actuator is moved from min to max. **THEN ALTER THE LENGTH OF THE ROD SLIGHTLY (PERHAPS .030"), SO THAT THE ACTUATOR IS JUST OFF ITS INTERNAL STOP, AND IS PULLING THE BUTTERFLY AGAINST ITS STOP.** This insures that the carb can fully close to idle on load dumps, minimizing overspeeds.

Examine the system for springs, such as carb. return springs. These should be removed. Some automotive carbs (as opposed to industrial carbs) contain internal springs for accelerator pumps, etc. These may make good governing difficult, or even impossible. For this, and other reasons, industrial carbs are much to be preferred.

Move the linkage slowly through its travel, and look for any binding or unexplained forces. Correct any before going further.

Many "governing" problems are really caused by binding of the butterfly and its shaft in the carb. This is caused by loading due to vacuum under the butterfly and atmospheric pressure above when the engine is running. These forces cannot be felt when the engine is not running. Therefore, start the engine while carefully controlling the speed by hand, and feel for binding or airload forces. Needle bearings on the butterfly shaft are available on many industrial carbs to deal with this problem. Any tendency of the butterfly to stick must be corrected.

MOUNTING-CONTROLLER

The Controller is water and weather resistant when the cover plate is filleted with RTV by the user. However, attention to the following points will enhance its performance and reliability;

Select a reasonably **cool, dry, and vibration free** location.

The rear cover will probably need to be removed during set-up in order to make adjustments for speed-setting and gain. You may wish to defer final installation until this is done.

After completing these adjustments, **replace** cover, and **seal** with a finger-fillet of RTV. Mount so that water cannot pool on this cover. Mounting with this cover out of sight discourages "fiddling".

WIRING

See wiring diagrams for details of hook-up.

Use #18 wire minimum, #16 is preferred.

If Governor is to be switched through the ignition switch, run power to the Governor directly via a dedicated #16 wire. Check that the wiring from the switch to the battery is at least #14 gage.

Keep all wiring to the Governor as short as is practical.

Go directly from the Controller ground terminal (B of the 8 pin connector) by dedicated wire, to the battery "minus" terminal. If this cannot be done, for some reason, go by dedicated wire to a **very** good engine ground.

A properly functioning engine electrical system will supply 13.5-14.8 VDC when the engine is running. If wiring size is adequate, with good connections and proper grounds, you will get this reading between the wires to terminals A & B of the 8 pin connector when the Governor is controlling engine speed. Verify this.

Improper hook-up can damage electronics. Re-check wiring *before* applying power.

WIRING DIAGRAM--GENERAL

See your machine wiring diagram for specific connections.

CHECK-OUT & INITIAL START-UP PROCEDURES

Assuming that the Actuator and Controller are mounted, the wiring is run and checked, and that the linkage is properly installed, proceed as follows:

- 1) Turn ignition switch **on**. Do not start engine.
- 2) Use Multimeter to check battery voltage at battery terminals, and record. Now check voltage at the machine connection points for terminals A & B of the 8 pin connector (A is +, B is -). This voltage reading should be the same as at battery. If not, shut down, and correct wiring.
- 3) Before proceeding, familiarize yourself with the locations of the **Speed Set** pot and the **Gain** pot. (See page 6.) Read the section on **Adjustments**, page 7.

4) Hold the linkage back by hand, so as to control engine speed manually. Start engine, set vehicle controls to obtain high engine speed, gradually release the linkage, and adjust the speed-set as needed to get the speed desired. If engine speed surges, reduce Gain a little, as required.

5) Re-check voltage between the connections for terminals A & B as in step 2. Voltage reading should be between 13.5--14.6 VDC. If less, look for undersized wiring somewhere in the system, or for other components wired in parallel with the Governor.

6) Carefully adjust **Gain**. You are looking for the best compromise between quick response and good stability. Make very small adjustments, then load and unload engine, or pull linkage back slightly and release. Usually, a good set-up is one that makes 1 to 3 small bounces and then steadies down after a large load change. Too much **Gain** shows up as a rapid (once per second) instability, most commonly at light loads. Too little **Gain** shows up in large over-shoots on start-up or large load changes, and generally sluggish operation.

7) Make final adjustment to the Speed-set.

8) Set machine controls to obtain the mid--engine speed. Adjust the mid-speed pot as needed to obtain the speed desired.

9) The starter lockout adjustment is factory set. If adjustment is necessary, the starter lockout pot may be adjusted to obtain dropout of the starter as the engine attains running speed. Normally this is around 500 RPM.

10) The overspeed is preset to the vehicle application. If necessary, it may be readjusted to shut off ignition power at a different engine speed by means of the overspeed adjustment pot.

11) Re-install the back cover on the E-331. Add a finger fillet of RTV around the edge of this cover to seal against dirt and moisture. Final-mount the controller.

E-331 ELECTRONICS--ADJUSTMENT LOCATIONS

Speed-set Starter Lockout Factory Adjust

Mid-speed Overspeed Gain

GOVERNOR ADJUSTMENTS

MULTI-TURN ADJUSTMENT (SPEED-SET, MID-SPEED, OVERSPEED, STARTER LOCKOUT)

This adjustment is made by turning the 1/8" brass screw clockwise (CW) to increase speed, and counterclockwise (CCW) to decrease speed. The adjustment range of the pot is 25 full turns, and one full turn will change speed about 100-200 rpm. This pot is protected by a slip clutch at each end, and will not be harmed by moderate over-adjustment. However, the Governor will not function while the pot is past full travel.

If you suspect you may have over-adjusted the Speed-set pot, or have lost track of where you are, turn the pot 25-30 turns CCW, then back 10-12 turns CW to get back into the range of normal adjustment.

SINGLE-TURN ADJUSTMENT (GAIN, FACTORY ADJUST)

This pot is 3/8" square and has a 1/8" plastic screw in its center. **Be gentle!** This pot turns 270°, and over-turning will break the internal stops, making adjustment impossible. Turning this pot CW increases Governor sensitivity, while turning CCW decreases sensitivity.

TROUBLESHOOTING

We will discuss Troubleshooting in two general categories:

- A) Governor won't work**
- B) Governor works, but can't be set up to give satisfactory performance**

There is, of course, some overlap between these categories. Read both sections and apply the fixes that seem appropriate.

During troubleshooting, be prepared to control the engine manually to prevent overspeeds, etc.

A. Governor won't work.

No reaction from Governor. Actuator output arm never moves, engine off or engine running. Can be caused by:

1. No power.
2. Incorrect linkage, preventing movement.
3. Incorrect electrical hook-up.
4. No speed signal to Governor.
5. Damaged Controller or Actuator.

1. No power Use a Multimeter to check for 12-15 VDC between terminals A & B of the 8 pin connector on the controller. Check during engine off and engine running conditions. If voltage is absent or low, check for:

- a. Wiring error
- b. Hook-up on wrong side of ballast resistor
- c. Low battery
- d. Bad Voltage Regulator
- e. Bad ground connection
- f. Corroded terminals
- g. Undersized wiring

2. Incorrect Linkage Recheck linkage as discussed on pages 2,3 and 4. Freedom of movement and lack of play are important.

- 3. Incorrect Electrical Hook-up** Re-check all wiring and connections to the Actuator and Controller against the vehicle schematic.

4. No speed signal to Controller

- with
- Check the voltage between terminals C & ground and D & ground of the 8 pin connector the engine running. You should see 5-30 VDC.
 - The above check does not guarantee a good speed signal, but their absence proves that there is a problem.

5. **Internal Governor fault** If steps 1-4 above have not revealed the problem, the Governor may have been damaged, either in shipping or during hook-up and test.

B. Governor reacts, but can't be set up to give proper performance

This kind of trouble usually falls into 3 main categories:

- Actual Governor malfunction
- Governor installation problems and improper installation
- Governor not tuned or adjusted for engine/application

1. **Actual Governor malfunction** The Governor was engine-tested for proper operation just prior to being shipped. Unless damaged in shipment or by improper handling, it should be serviceable. To check for proper operation, proceed as follows:

- low-
- Once again, disconnect fuel system linkage from Governor output arm and control engine manually.
 - Start engine, hold at a low speed. Governor arm should move to full-fuel position.
 - Increase engine speed carefully. At some engine speed, Governor arm should move to fuel position.
 - By carefully varying engine speed, you should be able to cause the Governor arm to pause momentarily near the middle of its travel. This engine speed is the set speed for which the Governor is adjusted. If grossly incorrect, reset **Speedset** pot.
 - With the engine running at low speed, move the governor arm throughout its stroke by hand. You should feel a constant smooth force in the *on* direction. No rubbing should be felt within the Governor.
- binding or

If steps 1a. through 1e. can be accomplished as described, the Governor is probably OK. It recognizes underspeed, overspeed, onspeed, and is not binding internally.

If the above steps cannot be accomplished satisfactorily, there is probably an actual Governor malfunction.

2. Installation and adjustment problems

- Governor is unable to move fuel system freely (not enough Actuator force available). If Governor doesn't move fuel system to *on* far enough to provide sufficient fuel, but Governor arm moves far enough when disconnected, look for:
 - Linkage binding or misadjusted.
 - Low voltage at Governor during operation*

*Measure the voltage as discussed previously and observe voltage during operation. If Governor fails to move full on and voltage dips over 1 volt, #16 minimum). check for undersize wire (should be
 - Excessive forces* at Governor during running, particularly on carbureted engines.

*Carburetor butterfly valves are loaded by engine vacuum during running, which can add considerable force not present when engine isn't running.

*Springs in the system: carburetor return springs, acceleration pump springs, etc., are not usually needed and can cause governing problems.
 - Governor may be too small for engine. Use next larger Actuator model.

- b. Governor is unstable at light-load or no-load, OK under heavy-load. See "Linkage", for carbureted engines.
- c. Governor experiences sudden, momentary spikes toward max. or min. at random intervals, then recovers.
 - 1. Look for loose wiring or momentary shorts in wiring.
 - 2. Noise or occasionally missing speed signal.
- d. Speed seems to slowly wander (5-15 second periods) around set speed, particularly at higher loads. See item 2a. 3 and item 2a.4 concerning excessive loads on Governor.

3. Governor not tuned or adjusted for engine/application

The basic adjustment to set sensitivity/stability is the Gain pot. A good starting point for many engines is full CCW, then CW 1/3 turn. (See "Governor adjustment" section.) To increase stability, turn CCW. If satisfactory governing cannot be achieved with this one adjustment, the **factory** adjustment may be needed. Normal starting point for this adjustment is fully CCW, then CW 1/4 turn . (Before changing this pot, the original position.)

mark